

Platinum Resistance Temperature Detector

HL 220

HL 220 type platinum sensors are characterised by long-term stability, precision over a broad temperature range and compatibility. The main feature is the small design. They are used in particular for applications with high consumption volumes, e.g. white goods and heating power.

Nominal Resistance R0	Tolerance DIN EN 60751 1996-07	Tolerance DIN EN 60751 2009-05	Order Number Plastic Box
1000 Ohm at 0°C	Class 2B	F 0.6	32 208 779

The measuring point for the nominal resistance is defined at 6mm from the end of the sensor body.

Specification	DIN EN 60751	
Temperature range	-70°C up to +750°C Tolerance Class 2B: -70°C up to +750°C	
Temperature coefficient	TC = 3850 ppm/K	
Leads	Pt coated NiCr- wire	
Lead lengths (L)	8mm ±1mm	
Long-term tests	R ₀ - Drift after 1000h at 750°C (energized) < 0,24% (Unhoused chip in standard atmosphere.)	
Environmental conditions	Unhoused for dry environmental only, above 500°C no reducing atmosphere, free air admission is necessary. Assembly can influence the long term stability!	
Vibration resistance	at least 40g acceleration at 10 to 2000 Hz, depends on installation	
Shock resistance	at least 100g acceleration with 8ms half sine wave, depends on installation	
Insulation resistance	> 100 MΩ at 20 °C; > 1 MΩ at 650 °C	
Self heating	0.2 K/mW	
Response time	Water current (v= 0.4m/s):	t _{0,5} = 0.05s t _{0,9} = 0.14s
	Air stream (v= 2m/s):	t _{0,5} = 3.0s t _{0,9} = 10s
Measuring current	0.1 to 1mA (self heating has to be considered)	
Note	Other tolerances, values of resistance and wire lengths are available on request.	

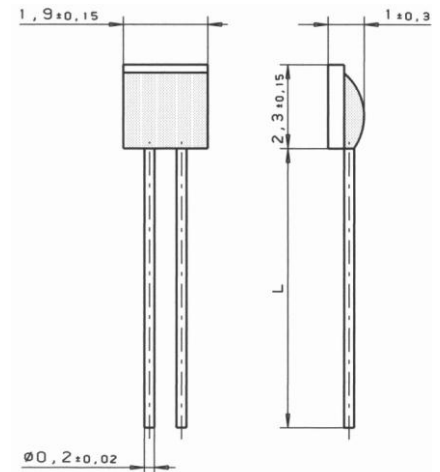

We reserve the right to make alterations and technical data printed. All technical data serves as a guideline and does not guarantee particular properties to any products.

Heraeus Sensor Technology GmbH, Reinhard- Heraeus- Ring 23, 63801 Kleinostheim, Germany
Phone: +49 (0) 6181/35-8098, Fax: +49 (0)6181/35-8101, E-Mail: info.HSND@Heraeus.com Web: www.heraeus-sensor-technology.com